

Cabin Class Divider CRJ 200

Benefits

Attractive, modern design, Easily movable by cabin crew to allow for changes in class sizes between flights

Kit Content

- LH & RH class divider
- Mounting rails
- All installation hardware
- Installation data package
- Certification documentation

Manpower

Approximately 50 man-hours are required to install the rails. Dividers are installed in minutes once rails are mounted.

Weight

Class divider & rails will add 73.5 lbs @ station X463.5 (with divider installed at station X418.14)

Certification Basis

Transport Canada STC
#SA01-52
EASA STC #ACG.21NE.049

www.fieldaero.com

1.905.676.1540

customersupport@fieldaero.com

- The FIELD AVIATION Cabin Class Divider STC kit provides a visual separation for two-class service in the passenger cabin.
- The class divider assembly consists of a clear polycarbonate panel that allows the flight attendants a clear view of all seat rows. As an option, a horizontal line or airline logo can be etched on the clear portion of the divider (pattern must be approved to ensure visibility is not adversely affected).
- The class divider attaches to two mounting rails (1.0" x 0.5" extrusion) that are installed under the left hand and right hand overhead storage bins. The mounting rails run from fuselage station X409+11 to the aft cabin bulkhead. A latch mechanism is provided at the inboard attach point to secure the divider in place.
- The divider can be installed at each seat back, except immediately forward of the underwing mid-cabin emergency exit, and can be installed immediately forward of the aft bulkhead when dual class service is not required.

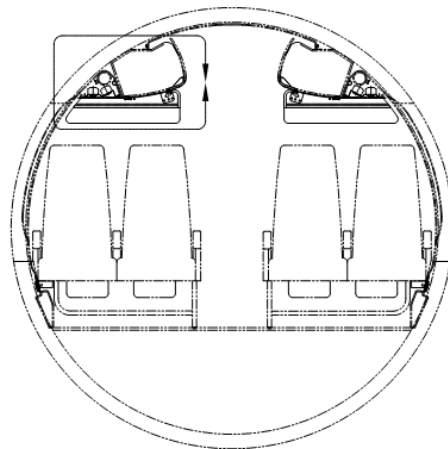

SECTION VIEW

LOOKING FORWARD WITH DIVIDERS INSTALLED

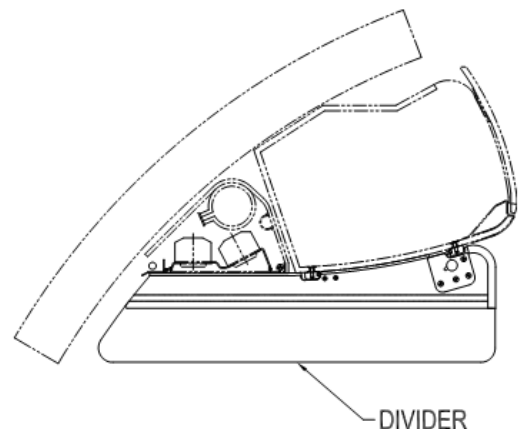

DETAIL VIEW

Kit Price and Delivery

Kit prices from US \$16,500 per aircraft. Additional charges will apply for deviations from existing design. Fleet volume discounts may apply. Typical lead time is approximately 12 weeks ARO.