

Auxiliary Power Unit (APU) Removal

DHC-8 400

Aircraft Applicability

- DHC-8-400

Benefits

- Allows the operator to continue operations while the APU is removed for maintenance or overhaul activities

STC Kit Content

- Removal/re-installation instructions
- Blanking plates & connector caps
- Installation data package
- Certification documentation

Typical Lead Time

- 3 weeks ARO

Certification Basis

- TC STC #SA11-37
- FAA STC #ST03016NY
- ESA STC #10036488

The Field Aerospace designed temporary Auxiliary Power Unit (APU) removal STC allows for continued operations of the aircraft with the APU removed.

The modification involves the removal of the APU Starter/Generator and the APU engine. The remaining APU system components such as the FADEC and APU Fuel Pump are disabled.

While the Bombardier Aircraft Maintenance Manual provides instructions for the removal of the APU while the aircraft is undergoing maintenance, it does not allow the aircraft to operate with the APU removed. In addition, the aircraft Minimum Equipment List (MEL) Procedures Manual does not list the APU and APU Bleed Air System as required equipment for dispatch and provides maintenance procedures for dispatch with the APU and APU Bleed Air System inoperative. These maintenance procedures are incorporated into this modification.

Removal of the APU involves the following:

- Removal of the APU, Starter Generator and miscellaneous accessories
- Capping and stowing the associated electrical harnesses
- Capping and stowing of fuel lines
- Blanking of the Engine Inlet Silencer
- Blanking of the APU Bleed Air Tube
- Installation of Placards
- Function check of the DC Power System

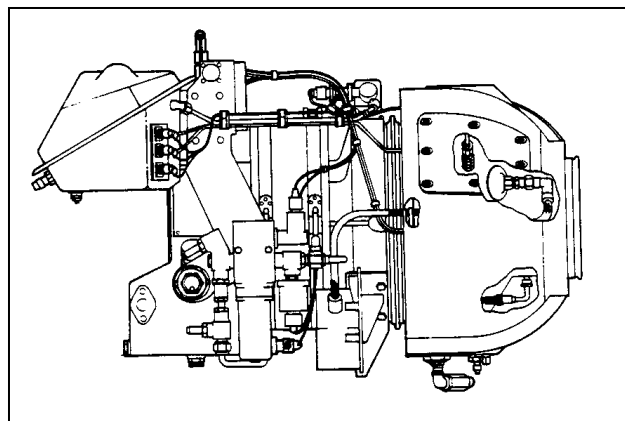

Delivery

Typical lead time is approximately 3 weeks ARO